

# **User's and Service Guide**

## **Agilent Technologies 85051B 7 mm Verification Kit**

This manual applies directly to 85051B Verification Kits that have serial number prefix 2815A. The verification devices in this kit are individually serialized.



**Manufacturing Part Number: 85051-90031**

**Printed in USA**

**Print Date: July 2007**

Supersedes: June 2002

© Copyright 1995, 2002, 2007 Agilent Technologies, Inc. All rights reserved.

---

## **WARRANTY STATEMENT**

THE MATERIAL CONTAINED IN THIS DOCUMENT IS PROVIDED “AS IS,” AND IS SUBJECT TO BEING CHANGED, WITHOUT NOTICE, IN FUTURE EDITIONS. FURTHER, TO THE MAXIMUM EXTENT PERMITTED BY APPLICABLE LAW, AGILENT DISCLAIMS ALL WARRANTIES, EITHER EXPRESS OR IMPLIED WITH REGARD TO THIS MANUAL AND ANY INFORMATION CONTAINED HEREIN, INCLUDING BUT NOT LIMITED TO THE IMPLIED WARRANTIES OF MERCHANTABILITY AND FITNESS FOR A PARTICULAR PURPOSE. AGILENT SHALL NOT BE LIABLE FOR ERRORS OR FOR INCIDENTAL OR CONSEQUENTIAL DAMAGES IN CONNECTION WITH THE FURNISHING, USE, OR PERFORMANCE OF THIS DOCUMENT OR ANY INFORMATION CONTAINED HEREIN. SHOULD AGILENT AND THE USER HAVE A SEPARATE WRITTEN AGREEMENT WITH WARRANTY TERMS COVERING THE MATERIAL IN THIS DOCUMENT THAT CONFLICT WITH THESE TERMS, THE WARRANTY TERMS IN THE SEPARATE AGREEMENT WILL CONTROL.

---

## **DFARS/Restricted Rights Notice**

If software is for use in the performance of a U.S. Government prime contract or subcontract, Software is delivered and licensed as “Commercial computer software” as defined in DFAR 252.227-7014 (June 1995), or as a “commercial item” as defined in FAR 2.101(a) or as “Restricted computer software” as defined in FAR 52.227-19 (June 1987) or any equivalent agency regulation or contract clause. Use, duplication or disclosure of Software is subject to Agilent Technologies’ standard commercial license terms, and non-DOD Departments and Agencies of the U.S. Government will receive no greater than Restricted Rights as defined in FAR 52.227-19(c)(1-2) (June 1987). U.S. Government users will receive no greater than Limited Rights as defined in FAR 52.227-14 (June 1987) or DFAR 252.227-7015 (b)(2) (November 1995), as applicable in any technical data.

---

## **Certification**

Agilent Technologies, Inc. certifies that this product met its published specifications at the time of shipment from the factory. Agilent Technologies, Inc. further certifies that its calibration measurements are traceable to the United States National Institute of Standards and Technology, to the extent allowed by the Institute's calibration facility, and to the calibration facilities of other International Standards Organization members.

---

## Assistance

Product maintenance agreements and other customer assistance agreements are available for Agilent products.

For any assistance, contact Agilent Technologies. Refer to “[Contacting Agilent](#)” on [page 6-5](#).

---

## Printing Copies of Documentation from the Web

To print copies of documentation from the Web, download the PDF file from the Agilent web site:

- Go to [www.agilent.com](http://www.agilent.com).
- Enter the document’s part number (located on the title page) in the **Search** box.
- Click Search.
- Click on the hyperlink for the document.
- Click the printer icon located in the tool bar.



**1. General Information**

Verification Kit Overview .....	1-2
Kit Contents .....	1-2
Calibration Definitions .....	1-2
Equipment Required but Not Supplied .....	1-3
Incoming Inspection .....	1-3
Recording the Device Serial Numbers .....	1-4
Preventive Maintenance .....	1-4

**2. Specifications**

Environmental Requirements .....	2-2
Temperature—What To Watch Out For .....	2-2
Mechanical Characteristics .....	2-3
Center Conductors .....	2-3
Airline Mechanical Characteristics .....	2-4
Electrical Specifications .....	2-6

**3. Duplicating Your Verification Data**

Using a PC or Your Network Analyzer to Duplicate the Verification Data Disks .....	3-2
Using an 8510C Network Analyzer .....	3-3
Using an 8719, 8720, or 8722 Series Network Analyzer .....	3-3
Using a PNA Series Network Analyzer .....	3-5

**4. Use, Maintenance, and Care of the Devices**

Electrostatic Discharge .....	4-2
Visual Inspection .....	4-3
Look for Obvious Defects and Damage First .....	4-3
Inspect the Mating Plane Surfaces .....	4-3
Cleaning Connectors .....	4-4
Gaging Connectors .....	4-6
Connector Gage Accuracy .....	4-6
When to Gage Connectors .....	4-6
Reading the Connector Gage .....	4-7
Gaging Procedure .....	4-8
Gaging the Airline .....	4-10
Making Connections .....	4-12
How to Make a Connection .....	4-12
Connecting the Airline .....	4-15
How to Separate a Connection .....	4-18
Handling and Storage .....	4-19

**5. Performance Verification**

Introduction .....	5-2
How Agilent Verifies the Devices in Your Kit .....	5-2
Recertification .....	5-3
How Often to Recertify .....	5-3

---

# Contents

Where to Send a Kit for Recertification . . . . . 5-3

## 6. Troubleshooting

Troubleshooting Process . . . . . 6-2  
Compatible Network Analyzers . . . . . 6-2  
Where to Look for More Information . . . . . 6-4  
Returning a Kit or Device to Agilent . . . . . 6-4  
Contacting Agilent . . . . . 6-5

## 7. Replaceable Parts

Introduction . . . . . 7-2

# 1 General Information

## Verification Kit Overview

The Agilent 85051B 7 mm verification kit provides a set of standards with known characteristics, traceable to a reference (golden) standard in Agilent Technologies calibration lab. This set of standards is used to verify your measurement calibration and also to verify that your network analyzer system is operating within its specifications. The frequency range covered by the 85051B is from 45 MHz to 18 GHz.

### Kit Contents

The 85051B verification kit includes the following items:

- 20 dB attenuator
- 50 dB attenuator
- 25Ω mismatch airline
- 50Ω airline
- open-end wrench
- storage box
- User's and Service Guide (this manual)
- three data disks that contain factory-measured verification data of the devices in this kit
- USB drive for PNA models that contains factory-measured verification data of the devices in this kit

Refer to [Chapter 7, "Replaceable Parts,"](#) for a complete list of kit contents and their associated part numbers.

A backup copy of each verification data disk should be made immediately upon receipt of the verification kit. Refer to [Chapter 3, "Duplicating Your Verification Data,"](#) for instructions on duplicating a disk.

---

**NOTE** A file containing the verification data for your kit is maintained for one year from the time of measurement. If you lose this data, contact Agilent. See ["Contacting Agilent" on page 6-5.](#)

---

### Calibration Definitions

The 85051B verification kit is intended to be used with the 85050B/C/D 7 mm calibration kits. Prior to performing a calibration with your network analyzer, the calibration kit must be selected and the calibration definitions for the devices in the kit installed in the network analyzer. Refer to your network analyzer user's guide for instructions on selecting the calibration kit and performing a calibration.

The calibration definitions can be:

- resident within the analyzer



- loaded from the provided disk
- entered from the front panel

Class assignments and standard definitions may change as more accurate model and calibration methods are developed. You can download the most recent class assignments and standard definitions from Agilent's Calibration Kit Definitions Web page at [www.na.tm.agilent.com/pna/caldefs/stddefs.html](http://www.na.tm.agilent.com/pna/caldefs/stddefs.html).

### **Installation of the Calibration Definitions**

The calibration definitions for the kit may be permanently installed in the internal memory or hard disk of the network analyzer.

If the calibration definitions for the kit are not permanently installed in the network analyzer, they must be manually entered. Refer to your network analyzer user's guide for instructions.

### **Equipment Required but Not Supplied**

Some items are not supplied with the verification kit but are required to ensure successful operation of the kit. Refer to [Table 7-2 on page 7-3](#) for a list of these items and for ordering information.

---

## **Incoming Inspection**

Verify that the shipment is complete by referring to [Table 7-1](#).

Check for damage. The foam-lined storage case provides protection during shipping. Verify that this case and its contents are not damaged.

If the case or any device appears damaged, or if the shipment is incomplete, contact Agilent Technologies. See [“Contacting Agilent” on page 6-5](#). Agilent will arrange for repair or replacement of incomplete or damaged shipments without waiting for a settlement from the transportation company. Refer to [“Returning a Kit or Device to Agilent” on page 6-4](#) for instructions.

## Recording the Device Serial Numbers

In addition to the kit serial number, the devices in this kit are individually serialized (serial numbers are labeled into the body of each device). Record these serial numbers in [Table 1-1](#). Recording the serial numbers will prevent confusing the devices in this kit with similar devices from other kits.

**Table 1-1 Serial Number Record for the 85051B**

Device	Serial Number
Verification kit	_____
20 dB attenuator	_____
50 dB attenuator	_____
50Ω airline	_____
25Ω mismatch airline	_____

---

## Preventive Maintenance

The best techniques for maintaining the integrity of the devices in this kit include:

- routine visual inspection
- cleaning
- proper gaging
- proper connection techniques

All of these are described in [Chapter 4](#), “[Use, Maintenance, and Care of the Devices.](#)” Failure to detect and remove dirt or metallic particles on a mating plane surface can degrade repeatability and accuracy and can damage any connector mated to it. Improper connections, resulting from pin depth values being out of specification (see [Table 2-2 on page 2-4](#)), or from bad connection techniques, can also damage these devices.

## **2 Specifications**

---

## Environmental Requirements

---

**NOTE** Samples of this product have been type-tested in accordance with the Agilent Environmental Test Manual and verified to be robust against the environmental stresses of storage, transportation and end-use; those stresses include but are not limited to temperature, humidity, shock, vibration, altitude and power-line conditions. Test methods are aligned with IEC 60068-2 and levels are similar to MIL-PRF-28800F Class 3.

---

**Table 2-1 Environmental Requirements**

Parameter	Required Values/Ranges
Temperature	
Operating <sup>a</sup>	+20 °C to +26 °C
Storage	–40 °C to +71 °C
Error-corrected range <sup>b</sup>	±1 °C of measurement calibration temperature
Altitude	
Operating	< 4,500 meters (≈15,000 feet)
Storage	< 15,000 meters (≈50,000 feet)
Relative humidity	Type tested, 0% to 95% at 40 °C, non-condensing

- a. The temperature range over which the calibration standards maintain conformance to their specifications.
- b. The allowable network analyzer ambient temperature drift during measurement calibration and during measurements when the network analyzer error correction is turned on. Also, the range over which the network analyzer maintains its specified performance while correction is turned on.

### Temperature—What To Watch Out For

Due to the small dimensions of the devices, electrical characteristics will change with temperature. Therefore, the operating temperature is a critical factor in their performance, and must be stable before use.

---

**IMPORTANT** Avoid unnecessary handling the devices during use because your fingers are a heat source.

---

## Mechanical Characteristics

Mechanical characteristics such as center conductor protrusion and airline dimensions are *not warranted* performance specifications. They are, however, important supplemental characteristics related to electrical performance. Agilent Technologies verifies the mechanical characteristics of the devices in this kit with special gaging processes and electrical testing. This ensures that the device connectors do not exhibit any improper pin depth when the kit leaves the factory.

“Gaging Connectors” on page 4-6 explains how to use gages to determine if the kit devices have maintained their mechanical integrity. Refer to Table 2-2 on page 2-4 for typical and observed pin depth limits.

### Center Conductors

In 7 mm connectors, the maximum allowable protrusion of the center conductor with the center conductor collet in place is 0.015 inches. The minimum protrusion required is 0.002 inches.

**Figure 2-1 7 mm Attenuators**

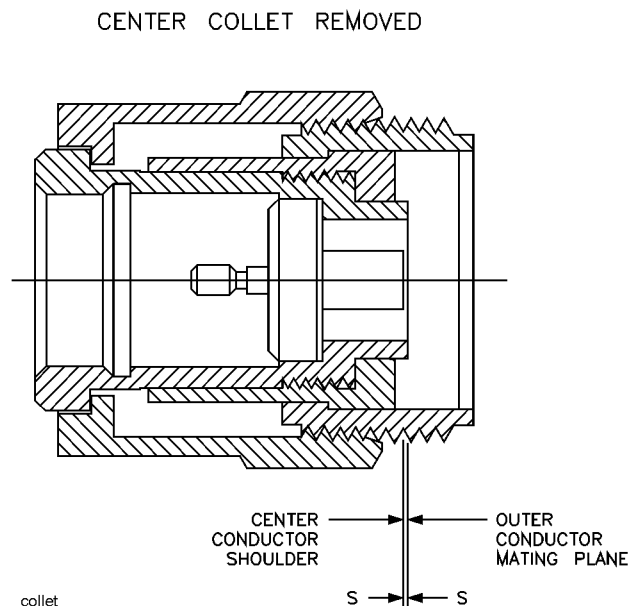

S = recession of the center conductor shoulder behind the outer conductor mating plane

**NOTE**      The factory uncertainty of the numbers given in the following table is less than  $\pm 0.0001$  inch. Gage accuracy is also  $\pm 0.0001$  inch.

**Table 2-2 Connector Pin Depths**

Connectors	Allowable Recession	
	millimeters	inches
Attenuators center collet removed	0.0000 to +0.0500	0.000 to +0.0020
Airlines <sup>a</sup> center pin removed	+0.0025 <sup>b</sup> to -0.0100	+0.0001 <sup>b</sup> to -0.0004

- a. The relationship between the length of the inner conductor and the length of the outer conductor determines the airline center conductor recession. Refer to [“Gaging the Airline” on page 4-10](#).
- b. In this case, the center conductor is 0.0001 inch (0.0025 mm) longer than the outer conductor.

Using these mechanical dimensions, you can calculate the expected electrical performance with the equations in the following publications:

- Nelson, Robert E., and Marlene R. Coryell, "Electrical Parameters of Precision, Coaxial, Air-Dielectric Transmission Lines", U.S. National Bureau of Standards Monograph No. 96.
- Somlo, P.L., "The Computation of Coaxial Line Step Capacitances", IEEE Transactions on Microwave Theory and Techniques, Volume MTT-15, No. 1, January, 1967.

The measurement method in these publications provides a general idea of the expected device characteristic impedance. Variations in connector interfaces can have a large effect on your actual electrical measurements.

## Airline Mechanical Characteristics

The dimensions of the airline outer conductor are shown in [Figure 2-2](#). This outer conductor is common to both airlines. Two conductors are provided with the kit.

The dimensions of the 50Ω airline and the 25Ω mismatch airline are shown in [Figure 2-3](#) and [Figure 2-4](#).

---

**CAUTION** The center and outer conductors of the airlines in this kit have been mechanically measured and matched. Do *not* use the center or outer conductors provided in this kit with a center or outer conductor from any other airline. Damage to the airline or attaching connector may result.

---

**Figure 2-2 Airline Outer Conductor**

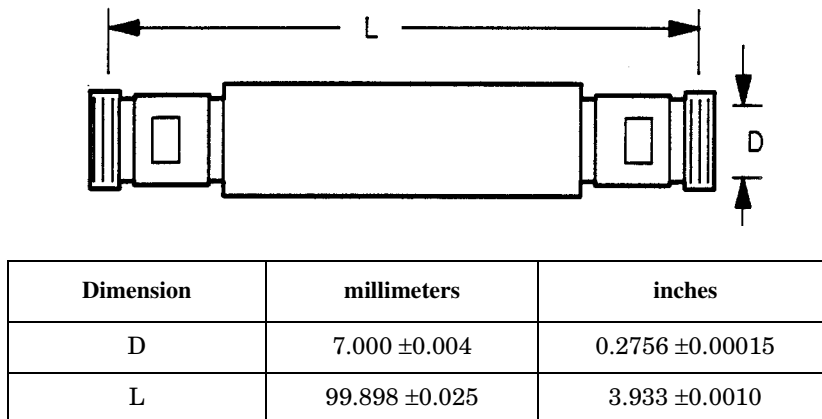

**Figure 2-3 50 $\Omega$  Airline Center Conductor**

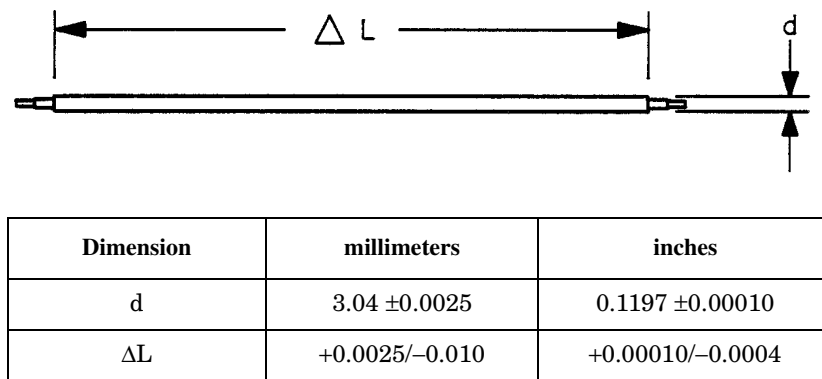

**Figure 2-4 25 $\Omega$  Mismatch Airline Center Conductor**

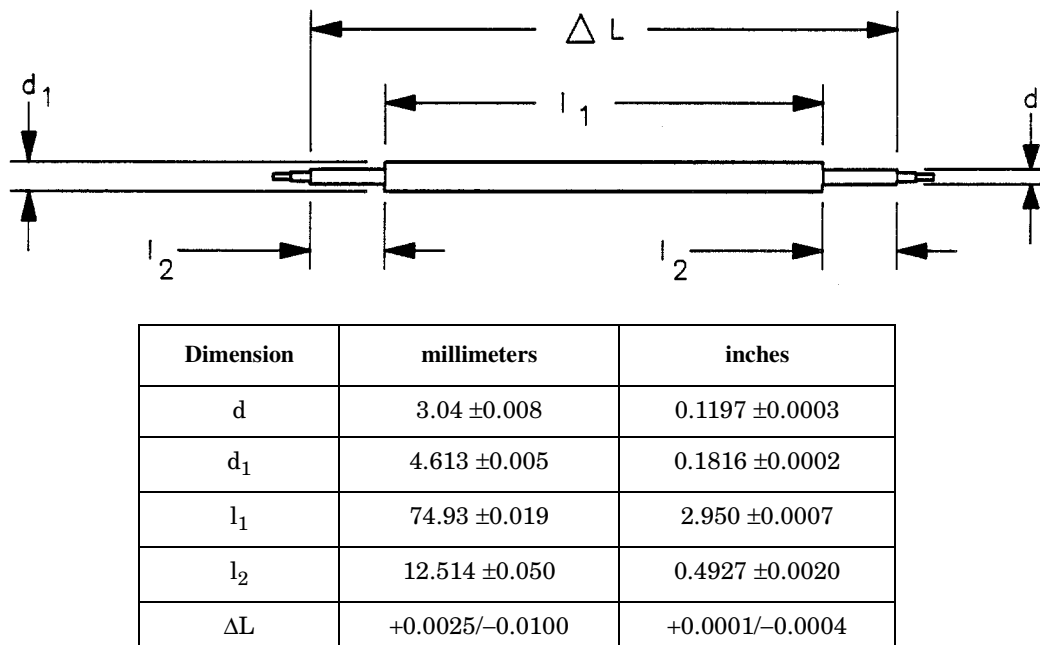

## Electrical Specifications

At the factory, each verification device is electrically characterized on a network analyzer measurement system. These factory measurements are traceable to the National Institute of Standards and Technology (NIST) through mechanical and electrical paths (for more information on traceability, contact Agilent Technologies. Refer to [“Contacting Agilent” on page 6-5](#)).

The factory-measured data for each device is supplied in print and on disk with your kit.



## **3 Duplicating Your Verification Data**

## **Using a PC or Your Network Analyzer to Duplicate the Verification Data Disks**

A backup copy of each verification data disk should be made immediately upon receipt of the verification kit. You may be able to use a personal computer (PC) to duplicate each disk. However, if the disk has LIF formatting, the PC will not be able to read it. If the PC is unable to read the disk, follow the instructions in this chapter to duplicate the disk using your network analyzer.

## Using an 8510C Network Analyzer

1. Initialize a blank disk:
  - a. Insert a blank disk in the 85101 disk drive and press **[TAPE/DISC]**.
  - b. Select **STORAGE IS INTERNAL, SETUP DISC, INITIALIZE DISC, YES**.
2. Insert the *original* data disk (it came in your verification kit) in the 85101 disk drive.
3. Press **[TAPE/DISC]** and select **LOAD, MEMORY ALL**. After you note the file numbers that have an asterisk next to them, select **FILE 1**.
4. When file 1 is through loading, remove the *original* disk and insert the blank, initialized disk in the disk drive.
5. Duplicate the S-Parameters:
  - a. Press **[TAPE/DISC]** and select **STORE, MEMORY ALL, FILE 1**.
  - b. Repeat steps 2 through 5a, substituting the next file number with an asterisk (noted in step 3) for **FILE 1** until all the files with an asterisk are copied on the new disk.
6. Duplicate the uncertainty limits:
  - a. Insert the *original* data disk in the disk drive.
  - b. Press **[LOAD]** and select **LOAD MEMORY 1-8**. Note the memory locations that have an asterisk next to them and select **1**.
  - c. Note the file numbers that have an asterisk next to them and select **FILE 1**.
  - d. When file 1 memory location 1 is through loading, remove the *original* disk and insert the blank, initialized disk in the disk drive.
  - e. Press **[TAPE/DISC]** and select **STORE, MEMORY 1-8, 1, FILE 1**.
  - f. Repeat steps 6a through 6e substituting the appropriate memory locations (noted in step 6b) and files (noted in step 6c) until all files in all memory locations are copied on the new disk.
7. Verify the new disk has duplicated properly by pressing **[TAPE/DISC]** and selecting **DIRECTORY**. The screen displays four **MEMORY ALL** files and four **MEMORY 1-8** files.
8. Remove the data disk from the disk drive.
9. Write-protect the disk and label it.

---

## Using an 8719, 8720, or 8722 Series Network Analyzer

1. Write-protect the master disk. To do this, slide the tab at the bottom edge of the disk so that the small square is open; you should be able to see through the square.
2. Write-enable the blank disk. To do this, slide the tab at the bottom edge of the disk so

that the small square is filled; you should *not* be able to see through the square.

3. Press **[PRESET]** on the analyzer.
4. Insert the blank disk in drive 0.
5. Insert the master disk in drive 1.
6. Press the following keys on the analyzer to initialize the blank disk:  
**[LOCAL], SYSTEM CONTROLLER.** The analyzer is now controlling the disk drive.  
**DISK, UNIT NUMBER, [0], [x1]** to select the blank disk.  
**[SAVE], STORE TO DISK, DEFINE STORE, INITIALIZE DISK, YES.** The blank disk is now initialized.
7. Press the following keys to get the first set of files from the master disk:  
**[LOCAL], DISK UNIT NUMBER, [1], [x1]**  
**[RECALL], LOAD FROM DISK, READ FILE TITLES.** The first set of file titles is now displayed beside the softkeys.
8. Press the following keys to load the first file into the analyzer:  
**[LOCAL], DISK UNIT NUMBER, [1], [x1]**  
**[RECALL], LOAD FROM DISK**  
**LOAD (filename)**
9. Press the following keys to store the first file onto the blank disk:  
**[LOCAL], DISK UNIT NUMBER, [0], [x1]**  
**[SAVE], STORE TO DISK**  
**STORE (filename)**
10. This sequence has transferred the first file from the master disk to the blank disk.  
Repeat steps 7 and 8 to transfer the other titles shown on the softkey labels.
11. Repeat steps 6, 7, and 8 until all sets of files have been transferred.

## **Using a PNA Series Network Analyzer**

The disk supplied for use with the PNA series analyzers is formatted using MS-DOS® and, therefore, can be duplicated on a personal computer (PC).

MS-DOS is a U.S. registered trademark of Microsoft Corporation.

Duplicating Your Verification Data  
**Using a PNA Series Network Analyzer**

## **4 Use, Maintenance, and Care of the Devices**

## Electrostatic Discharge

Protection against electrostatic discharge (ESD) is essential while connecting, inspecting, or cleaning connectors attached to a static-sensitive circuit (such as those found in test sets).

Static electricity can build up on your body and can easily damage sensitive internal circuit elements when discharged. Static discharges too small to be felt can cause permanent damage. Devices such as calibration components and devices under test (DUT), can also carry an electrostatic charge. To prevent damage to the test set, components, and devices:

- *always* wear a grounded wrist strap having a 1 M $\Omega$  resistor in series with it when handling components and devices or when making connections to the test set.
- *always* use a grounded, conductive table mat while making connections.
- *always* wear a heel strap when working in an area with a conductive floor. If you are uncertain about the conductivity of your floor, wear a heel strap.
- *always* ground the center conductor of a test cable before making a connection to the analyzer test port or other static-sensitive device. This can be done as follows:
  1. Connect a short (from your calibration kit) to one end of the cable to short the center conductor to the outer conductor.
  2. While wearing a grounded wrist strap, grasp the outer shell of the cable connector.
  3. Connect the other end of the cable to the test port.
  4. Remove the short from the cable.

Figure 4-1 shows a typical ESD protection setup using a grounded mat and a wrist strap. Refer to Table 7-2 on page 7-3 for information on ordering supplies for ESD protection.

**Figure 4-1 ESD Protection Setup**

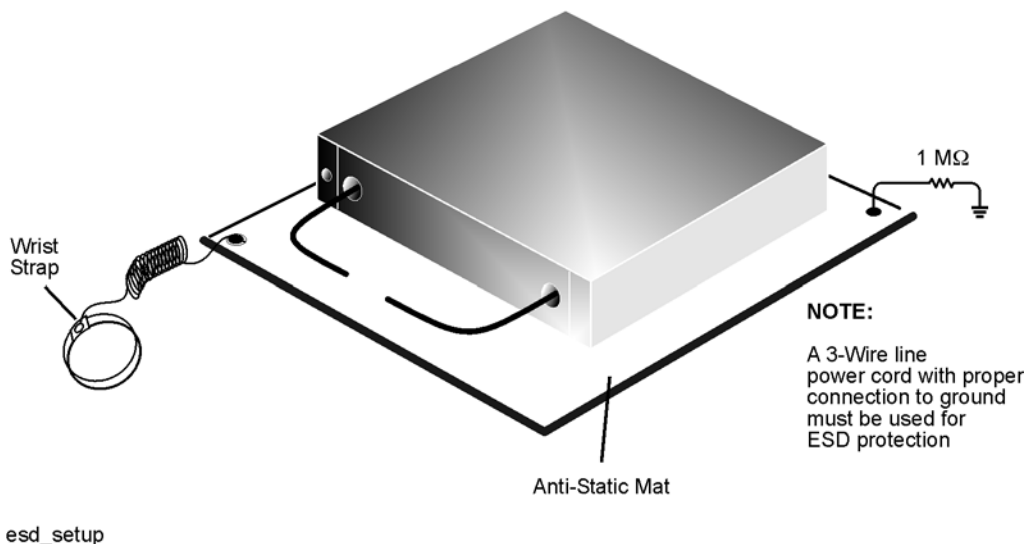



---

## Visual Inspection

Visual inspection and, if necessary, cleaning should be done every time a connection is made. Metal particles from the connector threads may fall into the connector when it is disconnected.

---

**CAUTION** Devices with damaged connectors should be immediately discarded or clearly marked and set aside for repair. A damaged device will in turn damage any good connector to which it is attached. Determine the cause of the damage before connecting a new, undamaged connector in the same configuration.

---

In some cases, magnification is necessary to see damage to a connector; a magnifying device with a magnification of  $\geq 10\times$  is recommended. However, not all defects that are visible only under magnification will affect the electrical performance of the connector. Use the following guidelines when evaluating the integrity of a connector.

### Look for Obvious Defects and Damage First

Examine the connectors first for obvious defects or damage: badly worn plating on the connector interface, deformed threads or bent, broken, or misaligned center conductors. Connector nuts should move smoothly and be free of burrs, loose metal particles, and rough spots.

### What Causes Connector Wear?

Connector wear is caused by connecting and disconnecting the devices. The more use a connector gets, the faster it wears and degrades. The wear is greatly accelerated when connectors are not kept clean, or are not connected properly.

Connector wear eventually degrades performance of the device. Calibration devices should have a long life if their use is on the order of a few times per week. Replace devices with worn connectors.

The test port connectors on the network analyzer test set may have many connections each day, and are therefore more subject to wear. It is recommended that an adapter be used as a test port saver to minimize the wear on the test set's test port connectors.

### Inspect the Mating Plane Surfaces

Flat contact between the connectors at all points on their mating plane surfaces is required for a good connection. Look especially for deep scratches or dents, and for dirt and metal particles on the connector mating plane surfaces. Also look for signs of damage due to excessive or uneven wear or misalignment.

Light burnishing of the mating plane surfaces is normal, and is evident as light scratches or shallow circular marks distributed more or less uniformly over the mating plane surface. Other small defects and cosmetic imperfections are also normal. None of these affect electrical or mechanical performance. If a connector shows deep scratches or dents, particles clinging to the mating plane surfaces, or uneven wear, clean and inspect it again.

## Cleaning Connectors

### 1. Use Compressed Air or Nitrogen

Clean connectors are essential for ensuring the integrity of RF and microwave coaxial connections.

---

**WARNING** Always use protective eyewear when using compressed air or nitrogen.

---

Use compressed air (or nitrogen) to loosen particles on the connector mating plane surfaces.

You can use any source of clean, dry, low-pressure compressed air or nitrogen that has an effective oil-vapor filter and liquid condensation trap placed just before the outlet hose.

Ground the hose nozzle to prevent electrostatic discharge, and set the air pressure to less than 414 kPa (60 psi) to control the velocity of the air stream. High-velocity streams of compressed air can cause electrostatic effects when directed into a connector. These electrostatic effects can damage the device. Refer to [“Electrostatic Discharge” on page 4-2](#) for additional information.

### 2. Clean the Connector Threads

---

**WARNING** Keep isopropyl alcohol away from heat, sparks, and flame. Store in a tightly closed container. It is extremely flammable. In case of fire, use alcohol foam, dry chemical, or carbon dioxide; water may be ineffective.

**Use isopropyl alcohol with adequate ventilation and avoid contact with eyes, skin, and clothing. It causes skin irritation, may cause eye damage, and is harmful if swallowed or inhaled. It may be harmful if absorbed through the skin. Wash thoroughly after handling.**

**In case of spill, soak up with sand or earth. Flush spill area with water.**

**Dispose of isopropyl alcohol in accordance with all applicable federal, state, and local environmental regulations.**

---

Use a lint-free swab or cleaning cloth moistened with isopropyl alcohol to remove any dirt or stubborn contaminants on a connector that cannot be removed with compressed air or nitrogen. Refer to [Table 7-2 on page 7-3](#) for a part number for cleaning swabs.

- a. Apply a small amount of isopropyl alcohol to a lint-free cleaning swab.
- b. Clean the connector threads.

- c. Let the alcohol evaporate, then blow the threads dry with a gentle stream of clean, low-pressure compressed air or nitrogen. Always completely dry a connector before you reassemble or use it.

### 3. Clean the Mating Plane Surfaces

- a. Apply a small amount of isopropyl alcohol to a lint-free cleaning swab.
- b. Clean the center and outer conductor mating plane surfaces. Refer to [Figure 2-1 on page 2-3](#). When cleaning a female connector, avoid snagging the swab on the center conductor contact fingers by using short strokes.
- c. Let the alcohol evaporate, then blow the connector dry with a gentle stream of clean, low-pressure compressed air or nitrogen. Always completely dry a connector before you reassemble or use it.

### 4. Inspect

Inspect the connector to make sure that no particles or residue remain. Refer to [“Visual Inspection” on page 4-3](#).

## Gaging Connectors

The gages available from Agilent Technologies are intended for preventive maintenance and troubleshooting purposes only. They are effective in detecting excessive center conductor protrusion or recession, and conductor damage on DUTs, test accessories, and the calibration kit devices. *Do not use the gages for precise pin depth measurements.*

### Connector Gage Accuracy

The connector gages are only capable of performing coarse measurements. They do not provide the degree of accuracy necessary to precisely measure the pin depth of the kit devices. This is partially due to the repeatability uncertainties that are associated with the measurement. Only the factory—through special gaging processes and electrical testing—can accurately verify the mechanical characteristics of the devices.

With proper technique, the gages are useful in detecting gross pin depth errors on device connectors. To achieve maximum accuracy, random errors must be reduced by taking the average of at least three measurements having different gage orientations on the connector. Even then, the resultant average can be in error by as much as  $\pm 0.0001$  inch due to systematic (biasing) errors usually resulting from worn gages and gage masters. As the gages undergo more use, the systematic errors can become more significant in the accuracy of the measurement.

### When to Gage Connectors

Gage a connector at the following times:

- Prior to using a device for the first time: record the pin depth measurement so that it can be compared with future readings. This serves as a good troubleshooting tool when you suspect damage may have occurred to the device.

---

**NOTE** When measuring pin depth, the measured value (resultant average of three or more measurements) is not necessarily the true value. Always compare the measured value with the *observed* pin depth limits (which account for measurement uncertainties) in [Table 2-2 on page 2-4](#) and with previously recorded values to evaluate the condition of device connectors.

---

- If either visual inspection or electrical performance suggests that the connector interface may be out of typical range (due to wear or damage, for example).
- If a verification device is used by someone else or on another system or piece of equipment.
- Initially after every 100 connections, and after that as often as experience indicates.

## Reading the Connector Gage

The gage dial is divided into increments of 0.0001 inch and major divisions of 0.001 inch (see [Figure 4-2](#)). For each revolution of the large dial, the smaller dial indicates a change of 0.01 inch. Use the small dial as the indicator of multiples of 0.01 inch. In most connector measuring applications, this value will be zero.

When making a measurement, the gage dial indicator will travel in one of two directions. If the center conductor is recessed from the *zero* reference plane, the indicator will move counterclockwise to indicate the amount of **recession**, which is read as a negative value. If the center conductor protrudes, the indicator will move clockwise to indicate the amount of **protrusion**, which is read as a positive value.

**Figure 4-2** Reading the Connector Gage

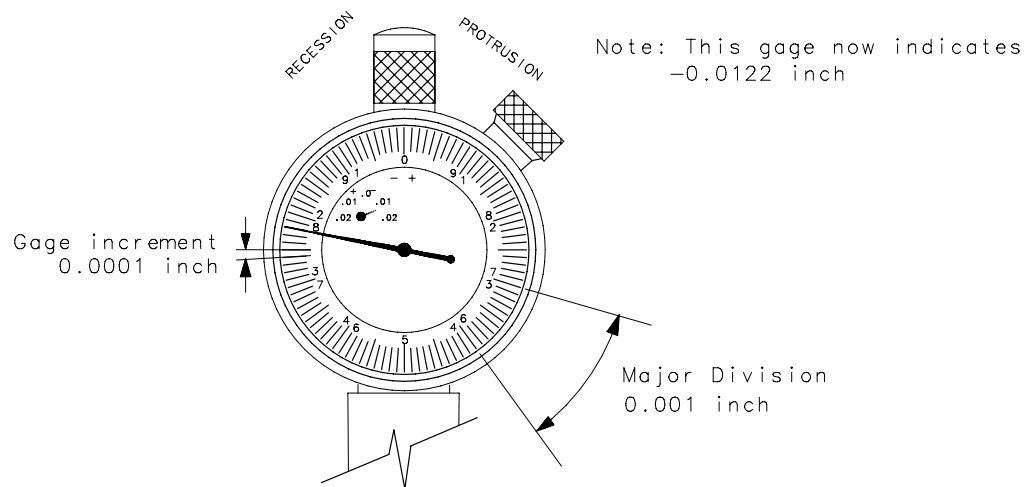

wj57f

## Gaging Procedure

---

**NOTE** Always hold a connector gage by the gage barrel, below the dial indicator. This gives the best stability, and improves measurement accuracy.

---

1. Select the proper gage for your connector. Refer to [Table 7-2 on page 7-3](#) for gage part number.
2. Inspect and clean the gage, gage master, and device to be gaged. Refer to [“Visual Inspection” on page 4-3](#) and [“Cleaning Connectors” on page 4-4](#) of this chapter.
3. Zero the connector gage (refer to [Figure 4-3](#)):
  - a. While holding the gage by the barrel, and without turning the gage or the device, connect the gage master to the gage. Refer to [“Making Connections” on page 4-12](#) for more information. Connect the nut finger tight. Do not overtighten.
  - b. Using an open-end wrench to keep the gage from rotating, use the torque wrench recommended for use with the kit to tighten the gage master connector nut to the specified torque. Refer to [“Final Connection Using a Torque Wrench” on page 4-12](#) for more information.
  - c. The gage pointer should line up exactly with the zero mark on the gage. If not, loosen the dial lock screw on the gage and rotate the gage dial so that the pointer is aligned with the zero mark.
  - d. Tighten the dial lock screw and remove the gage master.
  - e. Attach and torque the gage master to the gage once again to verify that the setting is repeatable. Remove the gage master.
4. Gage the device connector (refer to [Figure 4-3](#)):
  - a. While holding the gage by the barrel, and without turning the gage or the device, connect the gage master to the gage. Refer to [“Making Connections” on page 4-12](#) for more information. Connect the nut finger-tight. Do not overtighten.
  - b. Using an open-end wrench to keep the gage from rotating, use the torque wrench recommended for use with the kit to tighten the device connector nut to the specified torque. Refer to [“Final Connection Using a Torque Wrench” on page 4-12](#) for more information.
  - c. Gently tap the barrel of the gage with your finger to settle the gage reading.
  - d. Read the gage indicator dial. If the needle has moved clockwise, the center conductor is *protruding* by an amount indicated by the *black* numbers. If the needle has moved counterclockwise, the center conductor is *recessed* by an amount indicated by the *red* numbers.

For maximum accuracy, measure the connector a minimum of three times and take an average of the readings. After each measurement, rotate the gage a quarter-turn to reduce measurement variations that result from the gage or the connector face not being exactly perpendicular to the center axis.

- e. Compare the average reading with the pin depth specifications listed in [Table 2-2](#) on [page 2-4](#).
- f. Remove the device from the gage.

### Figure 4-3 Gaging 7 mm Connectors

#### Zero the Connector Gage

- Connect the gage master to the gage.
- Torque the connecting nut.
- Loosen the dial lock screw.
- Rotate the gage dial so that the pointer is aligned with the zero mark.
- Tighten the dial lock screw.
- Remove the gage master.

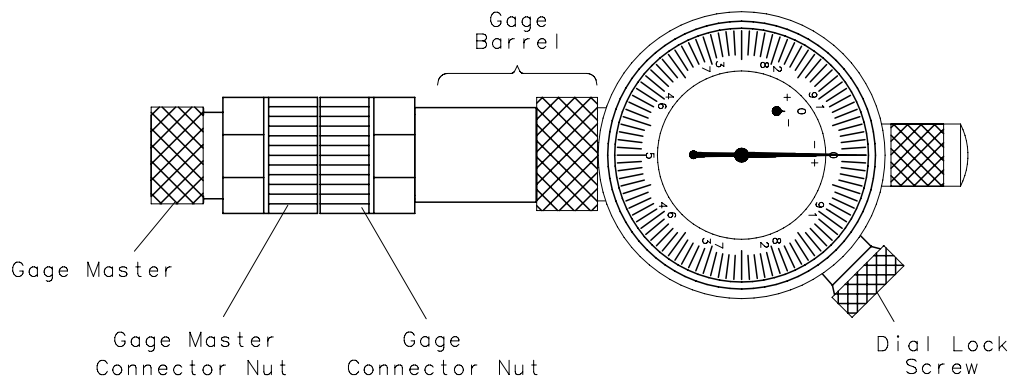

#### Gage the Device Connector

- Connect the device to the gage.
- Torque the connecting nut.
- Gently tap the gage barrel to settle the reading.
- Read recession or protrusion from the gage.
- Remove the device.
- Repeat two additional times and average the three readings.

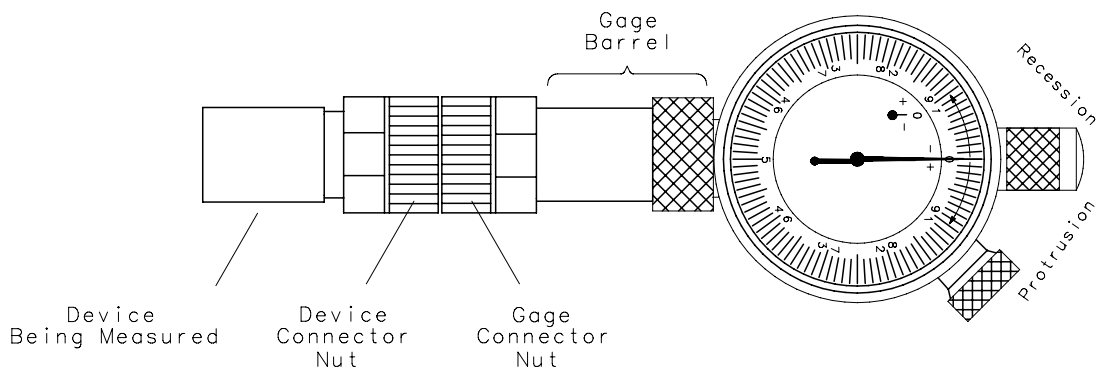

## Gaging the Airline

The airline center and outer conductor in this kit are measured and matched for length at the factory using special fixtures and gages. Because the gages supplied in the calibration kits do not have the accuracy of the factory gages, use the following procedure for very general results only. Perform this procedure whenever you suspect that a center conductor has been switched with another airline or that a device has been damaged.

### Attach the airline to the gage and short circuit

1. Inspect and, if required, clean the short, airline, and gage mating surfaces and threads.
2. Attach the short circuit from your calibration kit to the gage. Torque the connection to 136 N-cm, (12 in-lb). Refer to [Figure 4-4](#).

**Figure 4-4 Gaging the Short Circuit**

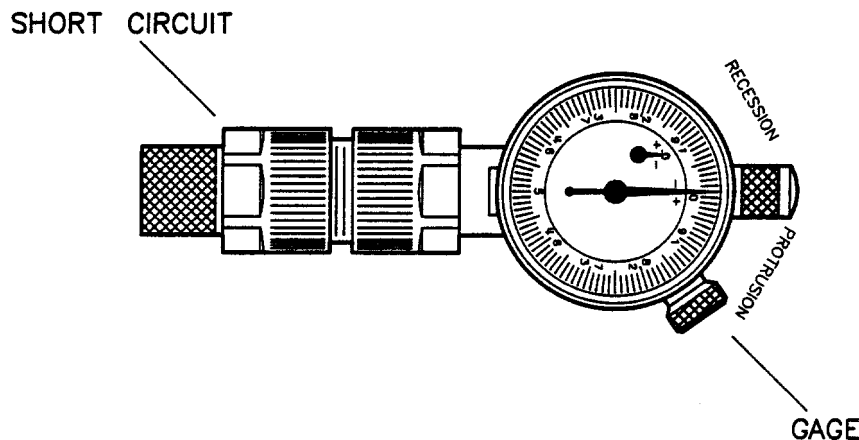

3. Gently tap the gage to settle the meter movement.
4. Adjust the dial on the gage to read flush (0.000) with the short circuit connected.
5. Remove the short circuit from the gage and attach the short circuit to the outer conductor of the airline. Refer to [Figure 4-5](#).
6. Remove the centering pins from the airline center conductor and slide the centering beads from the gage kit onto the airline center conductor.

---

**NOTE** This procedure refers to the “A” end of the airline as the end closest to the “A” in the Agilent logo on the label of the outer conductor. The other end will be referred to as the “B” end. See [Figure 4-8 on page 4-16](#).

---

7. Insert the center conductor into the outer conductor so that the mark on the center conductor is closest to the “A” end of the outer conductor. Do not let the center conductor scrape the edge of the outer conductor or damage may result.
8. Attach the gage to the other end of the airline. Refer to [Figure 4-5](#).



**Figure 4-5 Gaging the Airline**

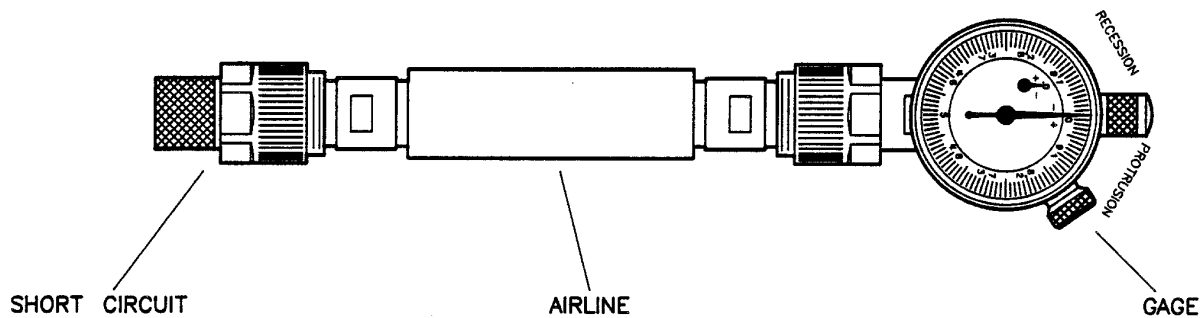

9. Torque the short circuit-to-airline connection and the gage-to-airline connection to 136 N-cm, (12 in-lb) with the 3/4 inch torque wrench. Set the assembly down to let the temperature stabilize for 5 minutes.
10. The reading on the gage should be within the tolerance band of the dimension given ( $\pm 0.0002$  inch);  $\pm 0.001$  inch for factory uncertainties and  $\pm 0.0001$  inch for your gage accuracy.

---

**NOTE** The reading on the gage is an estimate of the actual recession of the center conductor. Gage accuracy is typically  $\pm 0.0001$  inch.

---

**Disconnect the airline from the gage and short circuit**

1. Remove one device from the airline and replace the plastic cap on the airline to prevent the center conductor from sliding out of the outer conductor.
2. Remove the device from the other end of the airline. If you won't be using the airline again immediately, slide the center conductor out of the outer conductor and store the center conductor in the plastic case provided. Replace the other plastic cap on the outer conductor and store the center and outer conductors in the foam lined storage case.

## Making Connections

Good connections require a skilled operator. *The most common cause of measurement error is bad connections.* The following procedures illustrate how to make good connections.

### How to Make a Connection

#### Preliminary Connection

1. Ground yourself and all devices. Wear a grounded wrist strap and work on a grounded, conductive table mat. Refer to [“Electrostatic Discharge” on page 4-2](#) for ESD precautions.
2. Visually inspect the connectors. Refer to [“Visual Inspection” on page 4-3](#).
3. If necessary, clean the connectors. Refer to [“Cleaning Connectors” on page 4-4](#).
4. Use a connector gage to verify that all center conductors are within the pin depth specifications in [Table 2-2 on page 2-4](#). Refer to [“Gaging Connectors” on page 4-6](#).
5. Fully extend the connector sleeve on one of the connectors. Spin its knurled connector nut to make sure the threads are fully extended. Fully retract the sleeve on the other connector. The extended sleeve creates a cylinder into which the other connector fits.  
  
If one of the connectors is fixed (such as on a test port), fully extend that connector sleeve and fully retract the sleeve on the moveable connector.
6. Carefully align the connectors. As you make the actual connection, be sure the connectors align perfectly.
7. Push the connectors straight together. Do *not* twist or screw the connectors together.
8. Engage the connector nut (of the connector with the retracted sleeve) over the threads of the other connector (the connector with the extended sleeve). Turn only the connector nut. Let the connector nut pull the two connectors straight together.
9. Do not overtighten this connection. A connection in which the outer conductors make gentle contact at all points on both mating surfaces is sufficient. Very light finger pressure is enough to accomplish this.
10. Make sure the connectors are properly supported. Relieve any side pressure on the connection from long or heavy devices or cables.

#### Final Connection Using a Torque Wrench

Use a torque wrench to make a final connection. [Table 4-1](#) provides information about the torque wrench recommended for use with the calibration kit. A torque wrench is included in the calibration kit. Refer to [Table 7-2 on page 7-3](#) for part number and ordering

information.

**Table 4-1 Torque Wrench Information**

Connector Type	Torque Setting	Torque Tolerance
7 mm	136 N-cm (12 in-lb)	±13.6 N-cm (±1.2 in-lb)

Using a torque wrench guarantees that the connection is not too tight, preventing possible connector damage. It also guarantees that all connections are equally tight each time.

Prevent the rotation of anything other than the connector nut that you are tightening. It may be possible to do this by hand if one of the connectors is fixed (as on a test port). However, it is recommended that you use an open-end wrench to keep the body of the device from turning.

1. Position both wrenches within 90 degrees of each other before applying force. See [Figure 4-6](#). Wrenches opposing each other (greater than 90 degrees apart) will cause a lifting action which can misalign and stress the connections of the devices involved. This is especially true when several devices are connected together.

**Figure 4-6 Wrench Positions**

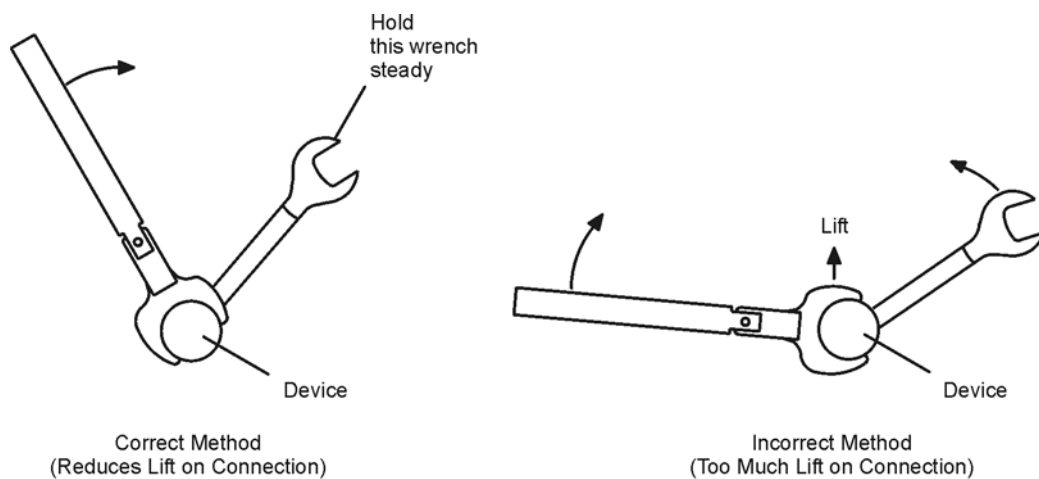

ph711a

2. Hold the torque wrench lightly, at the end of the handle only (beyond the groove). See [Figure 4-7](#).

**Figure 4-7 Using the Torque Wrench**

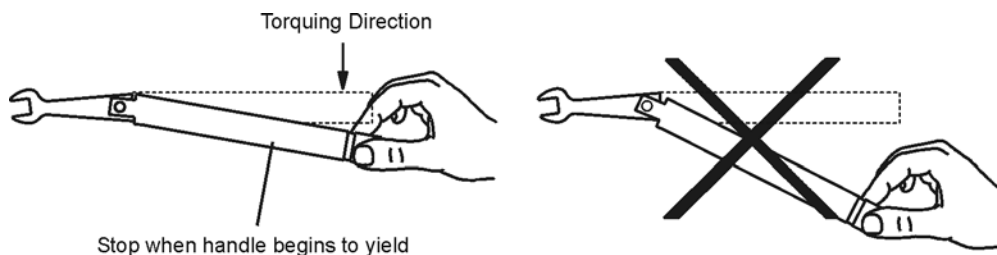

ph712a

3. Apply downward force perpendicular to the wrench handle. This applies torque to the connection through the wrench.

Do not hold the wrench so tightly that you push the handle straight down along its length rather than pivoting it, otherwise you apply an unknown amount of torque.

---

**CAUTION** You don't have to fully break the handle of the torque wrench to reach the specified torque; doing so can cause the handle to kick back and loosen the connection. Any give at all in the handle is sufficient torque.

---

4. Tighten the connection just to the torque wrench break point. The wrench handle gives way at its internal pivot point. See [Figure 4-7](#). Do not tighten the connection further.

## Connecting the Airline

### 50 $\Omega$ Airline and 25 $\Omega$ Mismatch Airline

---

**NOTE** Before making any connections to the test set, be sure that bias power to the test set is OFF and take care to avoid electrostatic discharge. Refer to [“Electrostatic Discharge” on page 4-2](#).

---

---

**CAUTION** Be especially careful not to drop either the center conductor or the outer conductor when handling these airlines. Irreparable damage will result if these devices are dropped.

---

---

**NOTE** Detachable spring-loaded tips are supplied with the center conductors of both the airline and mismatch airline in your 85051B kit. Do not use these tips when connecting the airlines to the TRL adapters supplied in the 85050C 7 mm Precision Calibration Kit.

When you are using these airlines to verify analyzer performance affected with the 85050 7 mm Precision Calibration Kit, substitute the normal tips with the special colleted spring-loaded tips. These tips are included in your 85050C Calibration Kit to allow proper contact between the center conductors of the airlines and the non-colleted TRL adaptors on the test ports. The colleted tips will not interfere when connecting the airlines to standard colleted test ports.

---

1. Connect test cables to port 1 and port 2 as they were connected during your calibration procedure.
2. Fully retract the threads on the port 1 cable connector.

---

**NOTE** This procedure refers to the “A” end of the airline as the end closest to the “A” in the Agilent logo on the label of the outer conductor. The other end will be referred to as the “B” end. See [Figure 4-8 on page 4-16](#).

---

**Figure 4-8 Airline Center Conductor Placement**

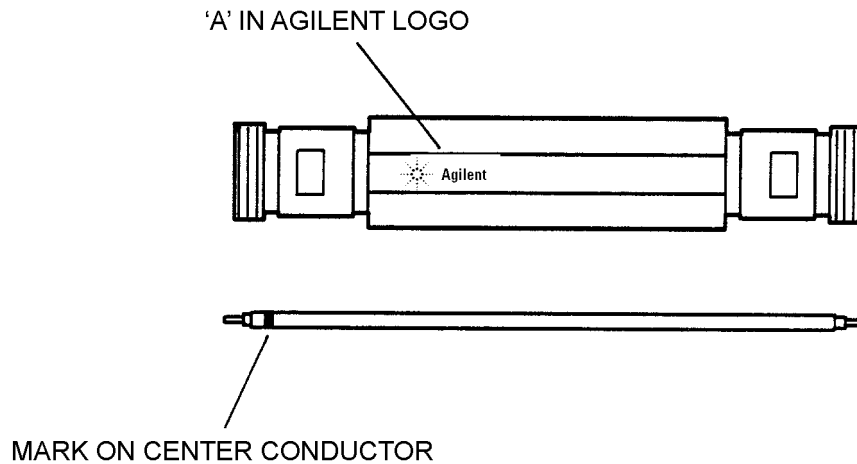

3. Remove the cap from the “A” end of the outer conductor. Leave the cap on the “B” end of the airline to prevent the center conductor from falling out of the airline.
4. Remove the center conductor from its plastic case. Make sure you select the correct center conductor for the airline you are connecting. Refer to [Figure 2-3](#) and [Figure 2-4 on page 2-5](#) for illustrations of both center conductors.
5. Insert the center conductor into the outer conductor so that the mark on the center conductor is closest to the “A” end of the outer conductor. See [Figure 4-8](#). Do not let the center conductor scrape the edge of the outer conductor or damage may result.
6. Bring the “A” end of the airline to the port 1 cable. Gently press on the cap at the “B” end of the airline so that the center conductor tip emerges from the “A” end of the airline. See [Figure 4-9](#).

**Figure 4-9 Airline**

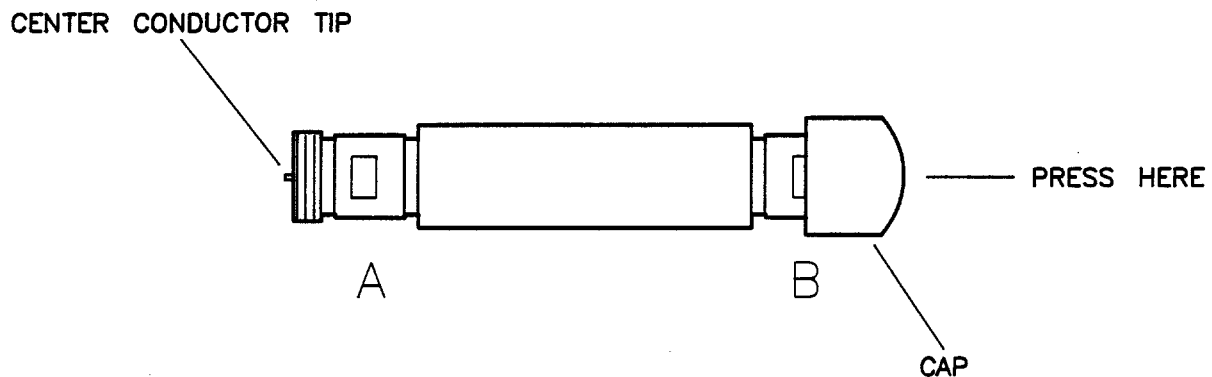

---

**NOTE** To avoid damaging the airline center conductor, always keep it in line with the connecting center pin.

---

7. Insert the tip of the center conductor (emerging from the “A” end) into the cable center conductor. See [Figure 4-10](#). Mate the outer conductors of the airline and port 1 cable connector finger tight.

**Figure 4-10 Connecting the Airline**

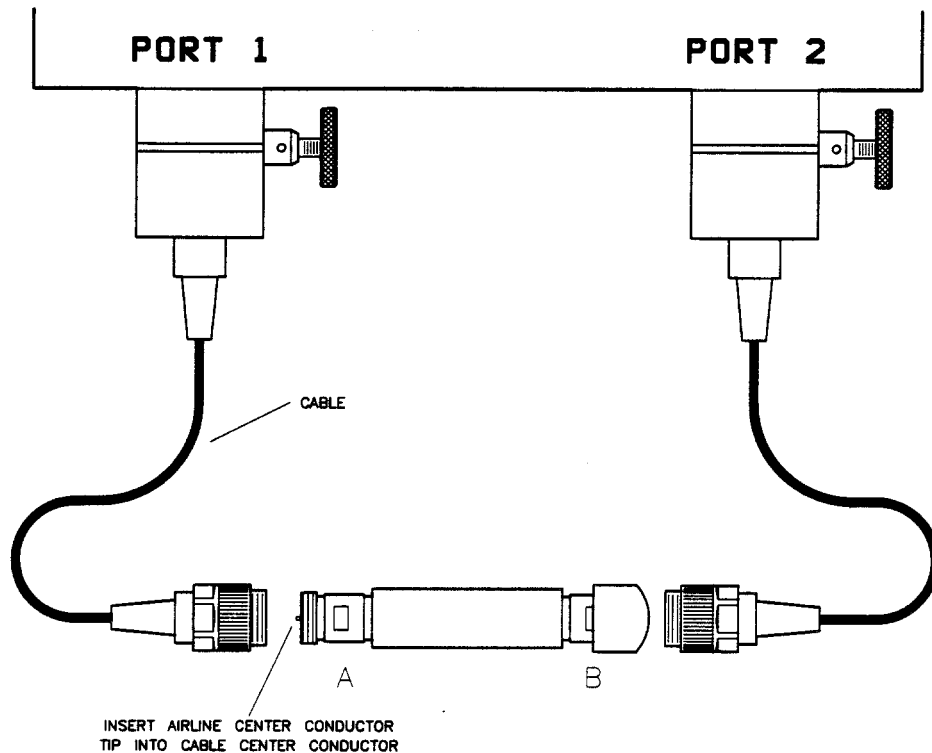

8. Gently remove the cap from the “B” end of the outer conductor. Fully retract the threads on the port 2 cable.
9. Align the center conductor of the port 2 cable connector with the center conductor of the airline. Insert the tip of the airline center conductor into the center conductor of the port 2 cable connector.
10. Mate the outer conductors of the port 2 cable connector and airline finger tight.
11. Torque the cable connectors as shown in [Figure 4-11 on page 4-18](#). To keep the airline from turning, either hold its plastic insulation or use an open end wrench while you torque the connection.

**Figure 4-11 Torquing the Connection**

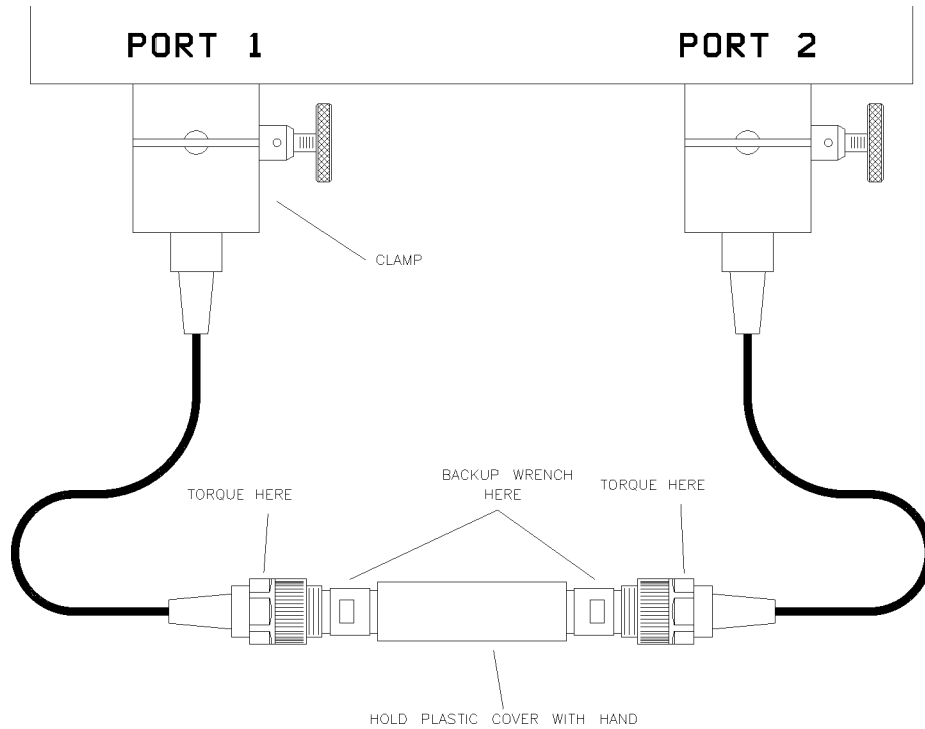

## How to Separate a Connection

---

**NOTE** Do not turn the device body. Only turn the connector nut. Damage to the center conductor can occur if the device body is rotated.

---

1. Use an open-end wrench to prevent the device body from turning.
2. Use another open-end wrench to loosen the connector nut.
3. Complete the disconnection by hand, turning only the connector nut.
4. Pull the connectors straight apart without twisting, rocking, or bending either of the connectors.

---

**NOTE** If disconnecting an airline and the airline center conductor does not disengage from the device center conductor, gently pull the center conductors apart and then push the airline center conductor back inside the outer conductor of the airline.

---



## Handling and Storage

- *Do* install the protective end caps and store the devices in the foam-lined storage case when not in use.
- *Do* keep connectors and airlines clean.
- *Do not* store connectors and airlines loose in a box, or in a desk or bench drawer. This is the most common cause of connector damage during storage.
- *Do not* touch mating plane surfaces. Natural skin oils and microscopic particles of dirt are easily transferred to a connector interface and are very difficult to remove.
- *Do not* set connectors contact-end down on a hard surface. The plating and the mating plane surfaces can be damaged if the interface comes in contact with any hard surface.



# **5 Performance Verification**

## Introduction

The performance of your verification kit can only be verified by returning the kit to Agilent Technologies for recertification. The equipment required to verify the specifications of the devices in the kit has been specially manufactured and is not commercially available.

---

## How Agilent Verifies the Devices in Your Kit

Agilent verifies the specifications of these devices as follows:

1. The residual microwave error terms of the test system are verified with precision airlines and shorts that are directly traced to the National Institute of Standards and Technology (NIST). The airline and short characteristics are developed from mechanical measurements. The mechanical measurements and material properties are carefully modeled to give very accurate electrical representation. The mechanical measurements are then traced to NIST through various plug and ring gages and other mechanical measurements.
2. Each device is electrically tested on this system. For the initial (before sale) testing of the devices, Agilent includes the test measurement uncertainty as a guardband to guarantee each device meets the published specification. For recertifications (after sale), no guardband is used and the measured data is compared directly with the specification to determine the pass or fail status. The measurement uncertainty for each device is, however, recorded in the calibration report that accompanies recertified kits.

These two steps establish a traceable link to NIST for Agilent to the extent allowed by the institute's calibration facility. The specifications data provided for the devices in the kit is traceable to NIST through Agilent Technologies.

---

## Recertification

The following will be provided with a recertified kit:

- a new calibration sticker affixed to the case
- a certificate of calibration
- a calibration report for each device in the kit listing measured values, specifications, and uncertainties

---

**NOTE** A list of NIST traceable numbers may be purchased upon request to be included in the calibration report.

---

Agilent Technologies offers a *Standard* calibration for the recertification of the kit. For more information, contact Agilent Technologies. See [“Contacting Agilent” on page 6-5](#).

### How Often to Recertify

The suggested initial interval for recertification is 12 months or sooner. The actual need for recertification depends on the use of the kit. After reviewing the results of the initial recertification, you may establish a different recertification interval that reflects the usage and wear of the kit.

---

**NOTE** The recertification interval should begin on the date the kit is *first used* after the recertification date.

---

### Where to Send a Kit for Recertification

Contact Agilent Technologies for information on where to send your kit for recertification. See [“Contacting Agilent” on page 6-5](#). Refer to [“Returning a Kit or Device to Agilent” on page 6-4](#) for details on sending your kit.



# 6 Troubleshooting

## Troubleshooting Process

If your network analyzer does not pass performance verification, follow the steps in [Figure 6-1](#) to determine the cause of the failure and the correct action to take to correct the failure.

---

## Compatible Network Analyzers

The devices in this kit and their data are compatible with the following network analyzers:

- 8510 Series
- 8719 Series, 8720 Series, and 8722 Series
- PNA Series

The data disk provided for use with each of the above listed network analyzers, and the USB drive provided for use with only the PNA Series, contains the factory-measured S-parameter data for the devices in this kit. It also contains the uncertainty limits used in the system verification procedure. This data is unique to each kit.

The data disk provided for the 8719 and 8720-series analyzers is for verification kits with the serial number 2815A or higher. Kits ordered prior to this serial prefix can be upgraded to include the data disk by recertifying the kit through Agilent. Refer to [“Contacting Agilent”](#) on page 6-5.

It is recommended that a backup copy of the data disk and the data printout be made immediately upon receipt of the verification disk. Refer to [Chapter 3](#), [“Duplicating Your Verification Data,”](#) for instructions.



Figure 6-1 Troubleshooting Flowchart

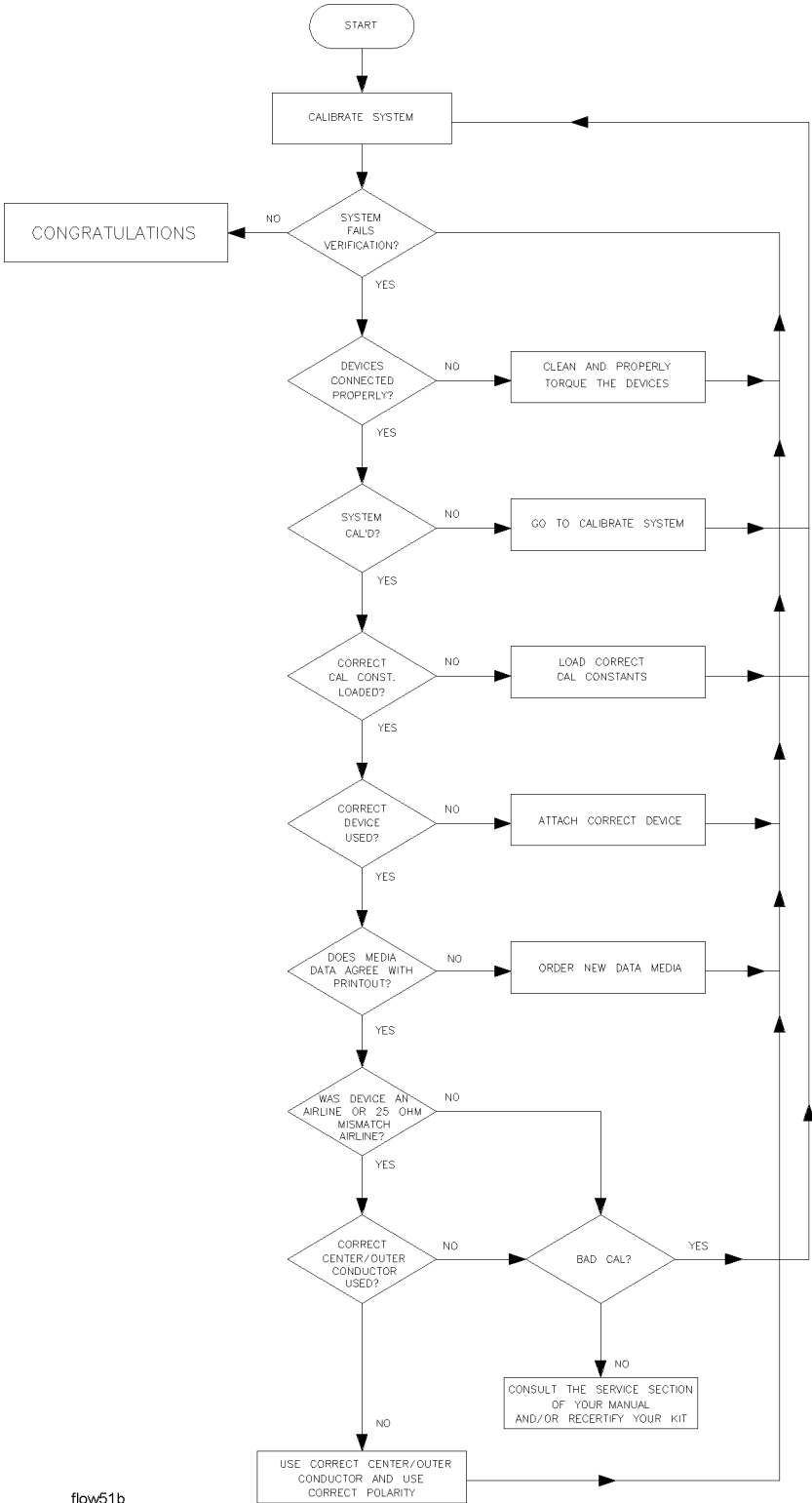

flow51b

## Where to Look for More Information

This manual contains limited information about network analyzer system operation. For detailed information on using a VNA, ENA or PNA series network analyzer, refer to the appropriate user guide or online Help.

- To view the ENA or PNA online Help, press the Help key on the front panel of the network analyzer.
- To view an online VNA user guide, use the following steps:
  1. Go to *www.agilent.com*.
  2. Enter your VNA model number (Ex: 8753ES) in the Search box and click **Search**.
  3. Under the heading **Manuals & Guides**, click on the title/hyperlink for the document PDF you want to view.

If you need additional information, see [“Contacting Agilent” on page 6-5](#).

---

## Returning a Kit or Device to Agilent

If your kit or device requires service, contact Agilent Technologies for information on where to send it. See [“Contacting Agilent” on page 6-5](#). Include a service tag (located near the end of this manual) on which you provide the following information:

- your company name and address
- a technical contact person within your company, and the person's complete telephone number
- the model number and serial number of the kit
- the part number and serial number of each device
- the type of service required
- a *detailed* description of the problem and how the device was being used when the problem occurred (such as calibration or measurement)

---

## Contacting Agilent

Assistance with test and measurements needs and information on finding a local Agilent office are available on the Web at:

[www.agilent.com/find/assist](http://www.agilent.com/find/assist)

If you do not have access to the Internet, please contact your Agilent field engineer.

---

**NOTE**      In any correspondence or telephone conversation, refer to the Agilent product by its model number and full serial number. With this information, the Agilent representative can determine whether your product is still within its warranty period.

---



## **7 Replaceable Parts**

---

## Introduction

Table 7-1 lists the replacement part numbers for items included in the 85051B verification kit.

Table 7-2 lists the replacement part numbers for items not included in the verification kit that are either required or recommended for successful operation of the kit.

To order a listed part, note the description, the part number, and the quantity desired. Telephone or send your order to Agilent Technologies. See “[Contacting Agilent](#)” on page 6-5.

**Table 7-1 Replaceable Parts for the 85051B 7 mm Verification Kit**

Description	Qty Per Kit	Agilent Part Number
<b>Attenuators</b>		
20 dB attenuator with data	1	85051-60001
50 dB attenuator with data	1	85051-60002
<b>Airlines</b>		
50Ω airline with data	1	85051-60010
25Ω mismatch airline with data	1	85051-60011
<b>Miscellaneous Items</b>		
Open-end wrench 9/16 in. and 1/2 in.	1	8710-1770
Storage box assembly	1	85051-60009
<b>User's and Service Guide</b>		
User's and service guide <sup>a</sup>	1	85051-90031
<b>Verification Data Media</b>		
Verification data disk (8510 series)	1	85051-10003

a. Refer to “[Printing Copies of Documentation from the Web](#)” on page -iii

**Table 7-2 Items Not Included in the Verification Kit**

Description	Qty	Agilent Part Number
<b>Connector Gages (7 mm)</b>		
7 mm gage set <sup>a</sup>	1	85050-80012
<b>Wrenches</b>		
3/4 in, 135 N-cm (12 in-lb) torque wrench <sup>b</sup>	1	8710-1766
7 mm collet extractor tool <sup>a</sup>	1	5060-0370
<b>Miscellaneous Items</b>		
7 mm short <sup>b</sup>	1	85050-80008 (85050C Cal Kit) –Or– 85050-80007 (85050B and 85050D Cal Kit)
<b>ESD Protection Devices</b>		
Grounding wrist strap <sup>b</sup>	1	9300-1367
5 ft grounding cord for wrist strap <sup>b</sup>	1	9300-0980
2 x 4 ft conductive table mat and 15 ft ground wire <sup>b</sup>	1	9300-0797
<b>Connector Cleaning Supplies</b>		
Anhydrous isopropyl alcohol (>92% pure) <sup>c</sup>	--	--
Cleaning swabs <sup>b</sup>	100	9301-1243

- a. Included in the 85050B and 85050C 7 mm calibration kits.
- b. Included in the 85050B, 85050C, and 85050D 7 mm calibration kits.
- c. Agilent can no longer safely ship isopropyl alcohol, so customers should purchase it locally.

**Figure 7-1** Replaceable Parts

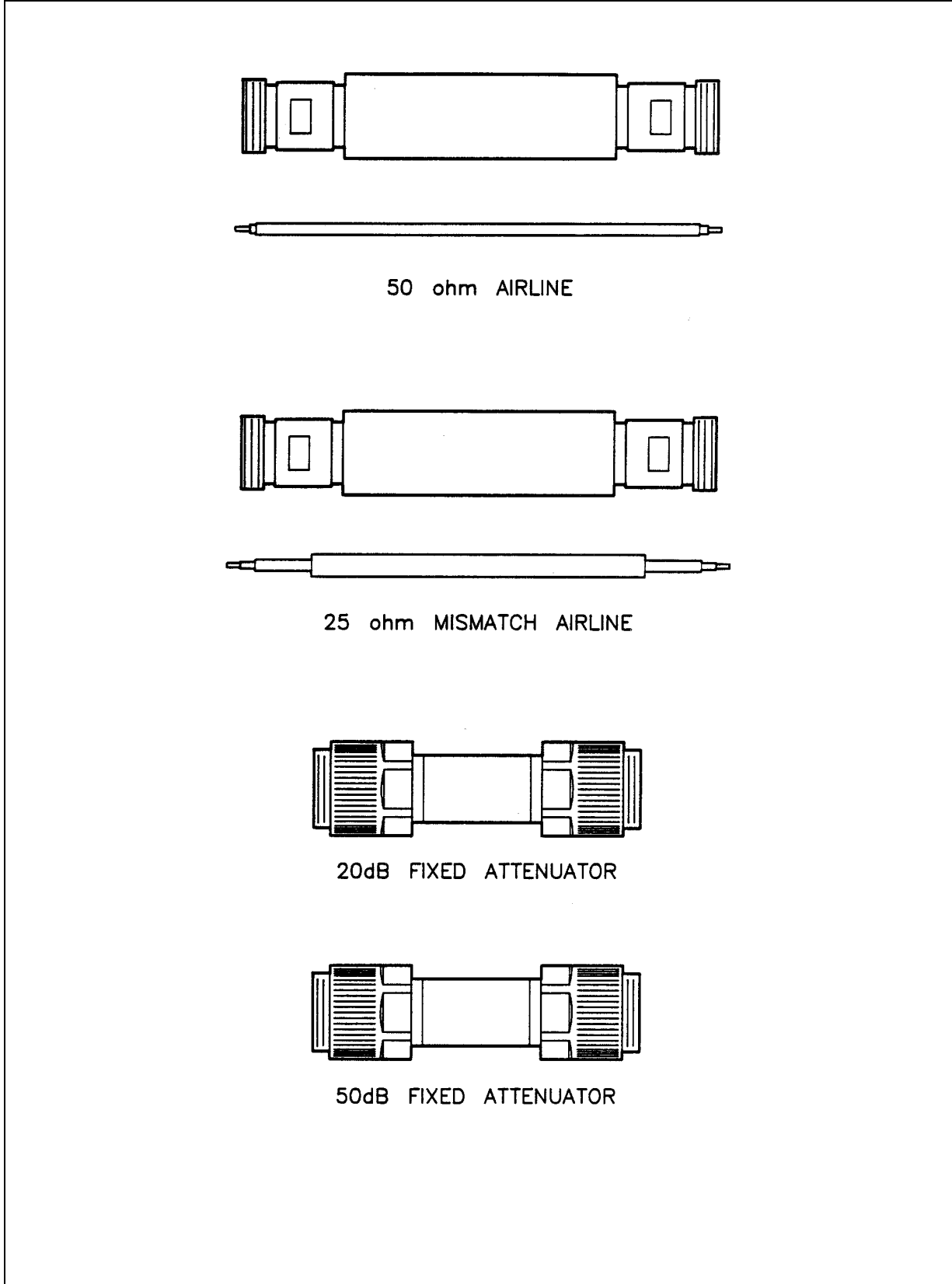



**Numerics**

25 ohm airline assembly and connection, [4-15](#)  
 50 ohm airline, assembly and connection, [4-15](#)

**A**

Agilent Technologies  
 contacting, [6-4](#), [6-5](#)  
 agreements  
 customer assistance, [-iii](#)  
 maintenance, [-iii](#)  
 airline  
 connection, [4-15](#)  
 dimensions, [2-4](#)  
 center conductor, [2-5](#)  
 outer conductor, [2-5](#)  
 disconnecting, [4-18](#)  
 gaging, [4-10](#)  
 mechanical characteristics, [2-4](#)  
 mismatch, [2-5](#)  
 part numbers, [7-2](#)  
 alcohol  
 isopropyl  
 as cleaning solvent, [4-4](#)  
 precautions for use of, [4-4](#)  
 altitude  
 specifications, [2-2](#)  
 assembling an airline, [4-15](#)  
 assistance  
 customer, [-iii](#)  
 who to contact, [-iii](#)  
 attenuators  
 part numbers, [7-2](#)

**B**

box  
 pads  
 part numbers, [7-2](#)  
 part number, [7-2](#)

**C**

calibration  
 bad, [6-2](#)  
 certificate of, [5-3](#)  
 constants, *See* calibration definitions  
 definitions  
 entering, [1-2](#)  
 permanently stored, [1-2](#)  
 kits  
 intended to be used, [1-2](#)  
 report, [5-3](#)  
 temperature, [2-2](#)  
 case  
 storage  
 part number, [7-2](#)  
 center conductor, [2-3](#)  
 protrusion, [4-7](#)  
 recession, [4-7](#)  
 certificate of calibration, [5-3](#)  
 characteristics

mechanical, [2-3](#)  
 supplemental, [2-3](#)  
 cleaning connectors, [4-4](#)  
 cleaning supplies, [1-3](#)  
 compatibility  
 with analyzers, [6-2](#)  
 compressed air or nitrogen, [4-4](#)  
 conductive table mat  
 for ESD protection, [4-2](#)  
 part number, [7-3](#)  
 conductor  
 center, [2-3](#)  
 mating plane, [2-3](#)  
 connecting an airline, [4-15](#)  
 connections, [4-2](#), [4-12](#)  
 ESD protection, [4-12](#)  
 final, [4-12](#)  
 preliminary, [4-12](#)  
 separating, [4-18](#)  
 using torque wrench, [4-12](#)  
 connector  
 cleaning, [4-4](#)  
 damage, [4-3](#)  
 defects, [4-3](#)  
 gage  
 accuracy, [4-6](#)  
 dial, [4-7](#)  
 handling, [4-6](#), [4-8](#)  
 part numbers, [7-3](#)  
 reading, [4-7](#)  
 use of, [4-6](#)  
 zeroing, [4-6](#), [4-8](#)  
 gaging, [4-6](#)  
 to determine pin depth, [4-6](#)  
 when to do, [4-6](#)  
 male, [4-8](#)  
 mating plane surfaces, [2-3](#), [4-5](#)  
 cleaning, [4-5](#)  
 threads  
 cleaning, [4-4](#)  
 inspecting, [4-3](#)  
 visual inspection, [4-3](#)  
 wear, [4-3](#)  
 affect on electrical performance, [4-3](#)  
 constants, calibration, *See* calibration definitions  
 contacting Agilent Technologies, [6-4](#)  
 copying verification data disks, [3-2](#)  
 cord  
 grounding  
 part number, [7-3](#)

**D**

damage  
 caused by electrostatic discharge, [4-2](#)  
 device, [4-3](#)  
 inspecting for, [1-3](#), [4-3](#)  
 to connectors, [4-3](#)  
 what to do, [1-3](#)  
 damaged connectors, [4-3](#)  
 data disk

---

# Index

- duplicating
    - 8510C, 3-3
    - 872x Series, 3-3
    - PNA Series, 3-5
  - verification
    - part number, 7-2
  - data recertification, 5-3
  - defective connectors, 4-3
  - defects
    - connector, 4-3
  - definitions
    - calibration, 1-2
  - device
    - compatibility
      - with analyzers, 6-2
    - conductor
      - mating plane, 2-3
    - connecting, 4-12
    - damage, 4-3
    - disconnecting, 4-18
    - handling, 4-19
    - maintenance, 1-4
    - performance
      - verifying, 5-2
    - specifications, 2-6
      - traceability, 5-2, 5-3
    - storage, 4-19
    - temperature, 2-2
    - visual inspection, 4-3
  - dial
    - connector gage, 4-7
  - dimensions
    - airline, 2-4
      - center conductor, 2-5
      - outer conductor, 2-5
    - device
      - center conductor, 2-3
      - outer conductor, 2-3
  - disconnections, 4-18
  - disk
    - duplicating
      - 8510C, 3-3
      - 872x Series, 3-3
      - PNA Series, 3-5
    - verification data
      - part number, 7-2
  - duplicating
    - verification disk
      - 872x Series, 3-3
      - PNA Series, 3-5
- E**
- electrical specifications, 2-6
  - electrostatic discharge, *See* ESD
  - environmental
    - regulations, 4-4
    - requirements, 2-2
    - specifications, 2-2
  - equipment required, 1-3
  - ESD, 4-2
    - conductive floor, 4-2
    - conductive table mat, 4-2
    - heel strap, 4-2
    - precautions, 4-2, 4-4
    - protection, 4-2
    - protection setup, 4-2
    - supplies, 4-2
      - part numbers, 7-3
    - wrist strap, 4-2
- F**
- flowchart
    - troubleshooting, 6-3
  - frequency range, 1-2
- G**
- gage
    - connector, 1-3
      - dial, 4-7
      - handling, 4-8
      - part numbers, 7-3
      - reading, 4-7
    - zeroing, 4-8
  - gaging
    - airline, 4-10
    - connectors, 4-6
      - when to do, 4-6
    - male connectors, 4-8
    - to determine pin depth, 4-6
  - grounding cord
    - part number, 7-3
- H**
- handling, 4-19
  - heel strap
    - for ESD protection, 4-2
  - humidity
    - specifications, 2-2
- I**
- incoming inspection, 1-3
  - information, troubleshooting, 6-4
  - inspection
    - damage, 4-3
    - defects, 4-3
    - incoming, 1-3
    - mating plane surfaces, 4-3
    - visual, 4-3
  - isopropyl alcohol
    - as cleaning solvent, 4-4
    - precautions for use of, 4-4
- K**
- kit
    - calibration
      - intended to be used, 1-2
    - contents, 1-2
    - frequency range, 1-2

overview, 1-2  
 performance  
   how Agilent verifies, 5-2  
   verifying, 5-2

**M**

maintenance, 4-2  
   agreements, -iii  
   of devices, 1-4  
   preventive, 1-4  
 making connections, 4-12  
   ESD protection, 4-12  
   precautions, 4-12  
 manual  
   part number, 7-2  
 mat  
   conductive  
     part number, 7-3  
     for ESD protection, 4-2  
 mating plane  
   conductor, 2-3  
   surfaces  
     cleaning, 4-5  
     connector, 4-5  
     inspection of, 4-3  
 mechanical characteristics, 2-3  
   verifying, 4-6  
 mechanical integrity, 2-3  
 mismatch airline, 2-5

**N**

National Institute of Standards and Technology  
 (NIST), 2-6, 5-2  
 nitrogen, 4-4  
 numbers  
   replaceable parts, 7-2  
   serial  
     recording, 1-4

**O**

open-end  
   wrench, 4-18  
     part number, 7-3  
 ordering parts, 7-2

**P**

part numbers, 7-2  
   of items in kit, 7-2  
   of items not in kit, 7-3  
 parts  
   included in kit, 7-2  
   not included in kit, 7-2, 7-3  
   ordering, 7-2  
   replaceable, 7-2  
 performance verification  
   fail, 6-2  
 permanently stored calibration definitions, 1-3  
 pin depth  
   definition of, 2-3

gaging to determine, 4-6  
   specifications, 2-4  
 preventive maintenance, 1-4  
 protrusion  
   center conductor, 4-7

**R**

reading connector gage, 4-7  
 recertification  
   how to order, 5-3  
   interval, 5-3  
   what's included, 5-3  
   where it's done, 5-3  
 recession  
   center conductor, 4-7  
 regulations  
   environmental, 4-4  
 replaceable parts, 7-2  
 report, calibration, 5-3  
 requirements  
   environmental, 2-2  
 return kit or device to Agilent, 6-4

**S**

separating connections, 4-18  
 serial numbers  
   devices, 1-4  
   recording, 1-4  
 service, 6-4  
 service tag, 6-4  
 shipment  
   verifying complete, 1-3  
 specifications, 2-2  
   altitude  
     operating, 2-2  
     storage, 2-2  
   device, 2-6  
   electrical, 2-6  
   environmental, 2-2  
   humidity, 2-2  
   pin depth, 2-4  
   temperature, 2-2  
   torque wrench, 4-12  
   traceability, 5-2, 5-3  
 standards  
   National Institute of Standards and Technology  
     (NIST), 5-2  
 static discharge, *See* ESD  
 storage, 4-19  
 storage case  
   part number, 7-2  
 strap  
   wrist  
     part number, 7-3  
 supplemental characteristics, 2-3  
 supplies  
   cleaning, 1-3

**T**

table mat

---

# Index

- for ESD protection, [4-2](#)
- tag
  - service, [6-4](#)
- temperature
  - affect on electrical performance, [2-2](#)
  - calibration, [2-2](#)
  - cautions about, [2-2](#)
  - changes in, [2-2](#)
  - device, [2-2](#)
  - error-corrected, [2-2](#)
  - measurement, [2-2](#)
  - specifications, [2-2](#)
    - operating, [2-2](#)
    - storage, [2-2](#)
  - verification and measurement, [2-2](#)
- test data, [5-3](#)
- threads
  - connector
    - cleaning, [4-4](#)
    - inspecting, [4-3](#)
- torque wrench, [1-3](#)
  - part number, [7-3](#)
  - specifications, [4-12](#)
- traceability
  - of device specifications, [5-2](#), [5-3](#)
- troubleshooting, [6-2](#)
  - flowchart, [6-3](#)

## U

- USB drive, [1-2](#)
- user's and service guide
  - part number, [7-2](#)
  - printing copies, [-iii](#)

## V

- verification
  - temperature, [2-2](#)
- verification data disk
  - duplicating
    - 8510C, [3-3](#)
    - 872x Series, [3-3](#)
    - PNA Series, [3-5](#)
  - part number, [7-2](#)
- verification kit
  - contents, [1-2](#)
  - frequency range, [1-2](#)
  - overview, [1-2](#)
  - performance
    - how Agilent verifies, [5-2](#)
    - verifying, [5-2](#)
- visual inspection, [4-3](#)

## W

- wear
  - connector, [4-3](#)
    - affect on electrical performance, [4-3](#)
- wrench
  - open-end, [1-3](#), [4-14](#), [4-18](#)
  - part number, [7-3](#)

- proper positioning of, [4-14](#)
- torque, [1-3](#), [4-12](#), [4-14](#)
  - part number, [7-3](#)
  - precautions for use of, [4-14](#)
  - proper use of, [4-14](#)
- wrist strap
  - for ESD protection, [4-2](#)
  - part number, [7-3](#)

## Z

- zeroing
  - connector gage, [4-8](#)